

FC Type Gate Valves

SWECO's FC gate valves feature a non-rising stem with a slab gate, floating seat ring body bushing design for safe and dependable service. It is available in flanged ends in standard bore sizes.

Features

Full-Bore Thru-Conduit Design

- Maximizes valve service life
- Eliminates the collection of destructive particles

Floating Slab Gate and Seats

- Produces a positive pressure energized seal
- Body pressure equalizes across the seat ring/body bushing, eliminating body erosion at the seat pockets

Metal to Metal Seals

- Body/bonnet interface, and gate/seat ring/body bushing interfaces, body/body bushing interface

In-line Repairability

- Seat rings, body bushings, gate and stem are easily replaced in the field

Metal to Metal Backseat

- Allows for body pressure containment in the case of stem packing leak

Long Life, Low Maintenance

- Simple routine maintenance program limits repairs, eases operation, protects against corrosion, and extends service life

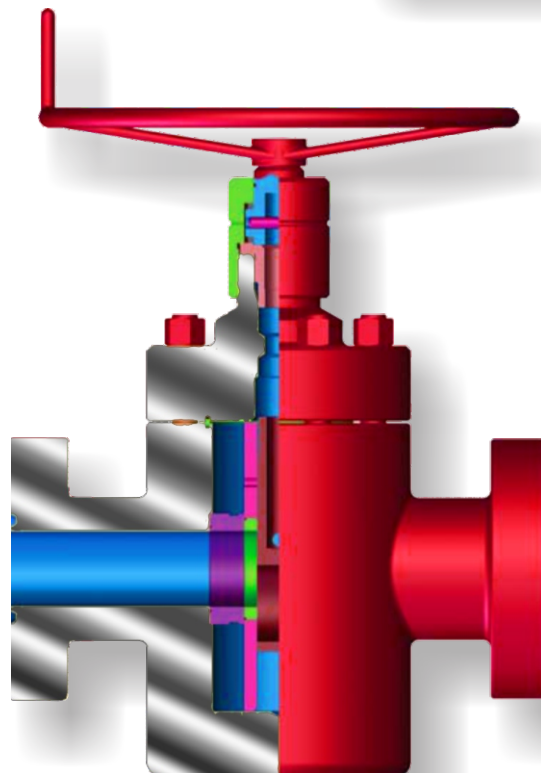
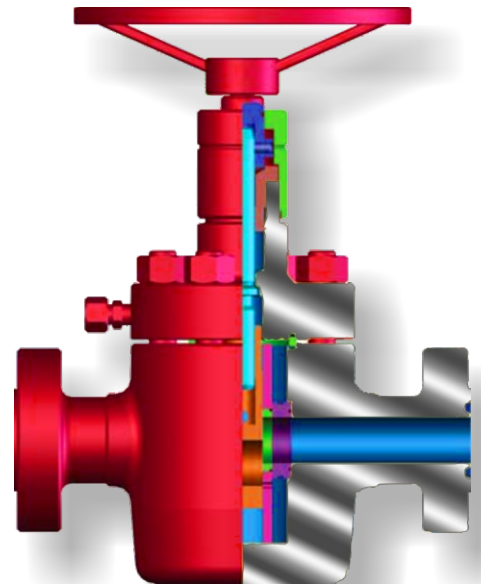

FC Type Gate Valves

Specifications

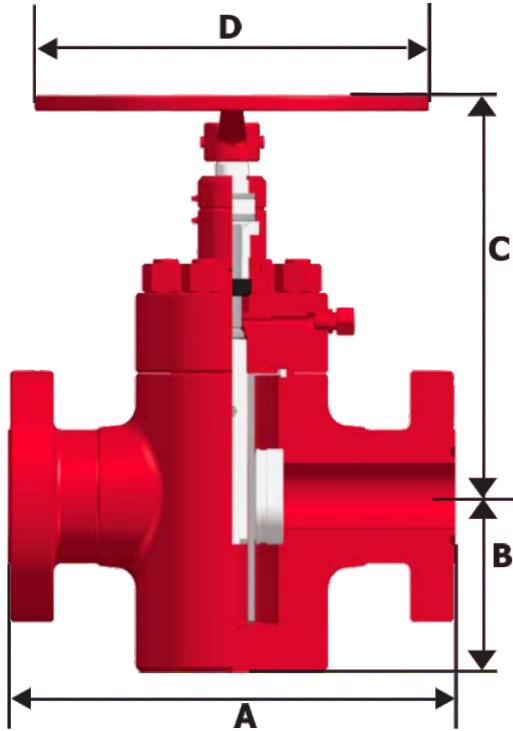

5,000 psi

Flange Size	A	B	C	D
2-1/16"	14.62"	5.62"	21.00"	14"
2-9/16"	16.62"	6.50"	21.81"	14"
3-1/8"	18.62"	7.38"	22.69"	18"
4-1/16"	21.62"	9.12"	24.31"	18"
7-1/16"	29.00"	12.75"	28.62"	24"

10,000 psi

Flange Size	A	B	C	D
1-13/16"	18.25"	5.75"	21.00"	14"
2-1/16"	20.50"	5.88"	21.00"	14"
2-9/16"	22.25"	6.81"	21.69"	18"
3-1/8"	24.38"	8.06"	22.75"	18"
4-1/16"	26.38"	10.06"	25.75"	24"
7-1/16"	35.00"	16.50"	33.25"	30"

15,000 psi

Flange Size	A	B	C	D
1-13/16"	18.25"	5.75"	21.00"	14"
2-1/16"	20.50"	5.88"	21.00"	14"
2-9/16"	22.25"	6.81"	21.69"	18"
3-1/8"	24.38"	8.06"	22.75"	18"
4-1/16"	26.38"	10.06"	25.75"	24"
7-1/16"	35.00"	16.50"	33.25"	30"

Trim Chart

Service Condition	Trim	Body	Bonnet	Gate	Seat	Stem
General, Non-Corrosive	AA	Alloy	Alloy	Alloy	Alloy	Alloy
General, Slightly Corrosive	BB	Alloy	Alloy	410 SS	410 SS	17-4 PH
General, Moderately Corrosive	CC	410 SS	410 SS	410 SS	410 SS	17-4 PH
Sour, Non-Corrosive	DD	Alloy	Alloy	Alloy	Alloy	17-4 PH
Sour, Slightly Corrosive	EE	Alloy	Alloy	410 SS	410 SS	17-4 PH
Sour, Moderately Corrosive	FF	410 SS	410 SS	410 SS	410 SS	17-4 PH